

RESIDUAL CURRENT RELAIS

DELTA



The range of Delta relais are the ideal for use in the industrial and service sectors, in public lighting and in building automatic machines, they comply with standards of protection CEI EN standard 60947-2 appendices B and M class A, anyway compatible with pulsing currents.

- ▶ The range of **Delta** modular, flush mounting and residual current relay in combination with current transformers Del and Del A (open core type), has the aim of protecting people and property while assuring system continuity of service.



Permanent connection control

An important feature of the Delta series is the permanent connection control of circuit between residual current relay and C.T.: by detecting of any anomaly in the connection between C.T. and E.L.R., the protection automatically intervenes, without waiting for the periodic check to carry out by test push button.

Δt intervention time adjustment







The Δt tripping time adjustment makes this series ideal for the creation of selective protection systems; adjustment in $I\Delta n$ current makes it possible to protect people and property against undesired or dangerous dispersions.

Version with harmonic filter

With the evolution of system requirements and the introduction into the systems of devices fitted with power electronics, the F models have been created with harmonic filter for systems that are subject to considerable disruption.

Residual current relay

Table of choice

								
Model		D2-I	D2-s	D4-s	D4-f	D4h	D4-l	48-s
Cat. nos.		RD1AF...	RD3AF...	RD4B2...	RD3B2...	RDD4...	RD2B213B	RD1DF...
Technical notes		NT544	NT597	NT871	NT865	NT897	NT748	NT556
Ranges	19: 0,03...30A	*	*	*	*		*	*
	18: 0,5...30A					*		
Istantaneous	t=0s a/at IΔn 30mA	*	*	*	*	*	*	*
Waveform	Sinusoidal (AC type)	*	*	*	*	*	*	*
	Chopped pulsating with superimposed dc (A type)	*	*	*	*	*	*	*
Filter for harmonics	Selectable				*	*	*	
	Fixed							
Reference standard	EN60947-2 IEC60947-2	*	*	*	*	*	*	*
Alarm	1 Relay Output	*	*		(2)			*
	2 Relays Output			(2)		*	*	
	1 Output + Pre-alarm			(2)	(2)		(2)	
IΔn display	LED Bargraph		*	*	*		*	
	Display					*		
Output relay	SPDT	*	*					*
	SPDT + SPST							
	2 SPDT			*	*	*	*	
Positive/negative safety	Selectable	*	*	*	*	*	*	*
Test	Local	*	*	*	*	*	*	*
	Remote	(1)	(1)	*	(1)	*		(1)
	Automatic	*	*	*	*	*	*	*
Reset	Local	*	*	*	*	*	*	*
	Remote	*	*	*	*	*	*	*
	Automatic	*	*	*		*		*
Auxiliary power supply	230Vac	*	*	*	*	*	*	*
	24-48-115-240-400Vac	*	*	*	*	*		*
	20...150Vdc	*	*	*	*	*		*
	10...36Vdc	*	*		*	*		
Dimensions	2 Module	*	*					
	4 Module			*	*	*	*	
	48 x 48 mm							*
	72 x 72 mm							
	96 x 96 mm							
Communication	RS485					*		
	RS232					*		
	Ethernet					*		

(1) Not available with aux. supply 20...150Vdc-48Vac

(2) On choice

Residual current relay

Residual current relay A type 2 module



DELTA D2-I



DELTA D2-s

Cat. Nos. **DELTA D2-I**

Instantaneous ($t = 0$) at $I_{\Delta n}$ 30mA
 Selectable set point
 30mA...30A (19 ranges)
 Field-selectable negative or positive security (fail safe)
 Automatic permanent test
 Manual or automatic reset (3 restart attempts)

	$I_{\Delta n}$ (A)	V_n	t (s)
RD1AF11B	0.03...30A	24Vac	0-0.15-0.25-0.5- 1-2.5-5
RD1AF12B		115Vac	
RD1AF13B		230Vac	
RD1AF15B		400Vac	
RD1AF1HB		20...150Vdc + 48Vac	

Cat. Nos. **DELTA D2-s with LED bar**

Instantaneous ($t = 0$) at $I_{\Delta n}$ 30mA
 Selectable set point
 30mA...30A (19 ranges)
 Instantaneous display as percentage of $I_{\Delta n}$
 Field-selectable negative or positive security (fail safe)
 Automatic permanent test
 Manual or automatic reset (3 restart attempts)

	$I_{\Delta n}$ (A)	V_n	t (s)
RD3AF11B	0.03...30A	24Vac	0-0.15-0.25-0.5- 1-2.5-5
RD3AF12B		115Vac	
RD3AF13B		230Vac	
RD3AF15B		400Vac	
RD3AF1HB		20...150Vdc + 48Vac	

Technical features

MODEL	DELTA D2-L	DELTA D2-S
TECHNICAL NOTES	NT544	NT597
INPUT		
Reference specification:	EN60947-2 IEC60947-2	
Connection:	low voltage lines, with series TD transformer	
Waveform $I_{\Delta n}$:	sinusoidal (type AC) or chopped pulsating with superimposed dc (type A) according to EN60947-2 (annex B and M) IEC60947-2	
Rated frequency f_n :	50Hz	
Working frequency:	47...63Hz	
SET UP		
Current set point $I_{\Delta n}$:	selectable by 7-position potentiometer, 3 ranges x1 - x10 - x100	
Ranges $I_{\Delta n}$:	0.03 - 0.05 - 0.075 - 0.1 - 0.15 - 0.2 - 0.3 (x1 - x10 - x100)	
Non-operating residual current:	0.5 $I_{\Delta n}$	
Adjustable Intervention time t :	0 - 0.15 - 0.25 - 0.5 - 1 - 2.5 - 5 sec	
SIGNALING AND ALARM		
Power ON:	green LED "ON"	
Instantaneous value $I_{\Delta n}$:	-	3 LED's, 20 - 40 - 60% of set $I_{\Delta n}$ value (DELTA D2-S only)
Alarm intervention:	red LED "TRIP" + relay switching	
Ring current transformer-relay connection failure:	red LED "TRIP" blinking + relay switching	
TRIP state memorization:	1 red LED "TRIP" + relay self-retaining 1 excluded with automatic reset	
Reset:	manual or automatic, selectable by dip switch	
Local manual:	front key	
Remote manual:	external contact closing	
Automatic:	3 restart attempts (1 each 60 seconds)	
Inhibited reset with persistent residual current:	> 50% $I_{\Delta n}$	
OUTPUT		
Relay:	1 SPDT contact	
Contact range:	5A 250Vac $\cos\phi$ 1 - 3A 250Vac $\cos\phi$ 0.4 - 5A 30Vdc	
Negative security (normally de-energised relay) or positive security fail safe (normally energised relay): selectable by dip switch		
AUXILIARY SUPPLY		
Rated value U_{aux} :	24V - 48V - 115V - 230V - 240V - 400V	
Tolerance:	0,85...1,1 U_{aux} - 40...60V (U_{aux} 48V)	
Rated frequency:	50Hz (47...63Hz)	
Rated burden:	\leq 2.5VA	
Rated value U_{aux} :	20...150Vdc	
Protected against incorrect polarity	yes	
Rated burden:	\leq 2.5W	
Immunity to short interruption of supply voltage up to 300ms (Rated U_{aux})		
TESTS FOR ELECTROMAGNETIC COMPATIBILITY		
Emission/Immunity tests according to	EN / IEC 60947-2	
ENVIRONMENTAL CONDITIONS		
Nominal temperature range:	-5...50°C	
Limit temperature range for storage:	-40...70°C	
Suitable for tropical climates:	yes	
Max. power dissipation:	\leq 2W *	
MECHANICAL FEATURES		
Housing:	2 module DIN 43880 (35mm)	
Front frame:	sealable to avoid improper opening	
Connections:	screw terminals for cable up to 4 mm ²	
Housing material:	self-extinguishing polycarbon ate	
Protection degree (EN / IEC 60529):	IP50 front frame, IP20 terminals	

* for switchboard thermal calculation

Wiring diagrams

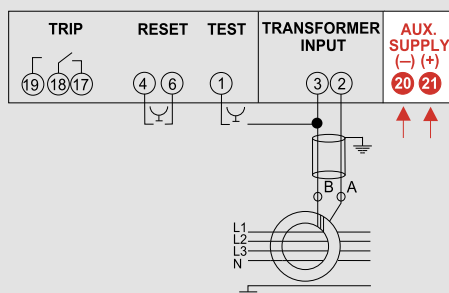

Residual current relay

Residual current relay A type 4 module



Cat. Nos.

DELTA D4-s

Instantaneous ($t = 0$) at $I_{\Delta n}$ 30mA
 Selectable set point 30mA...30A (19 ranges)
 Instantaneous display as percentage of $I_{\Delta n}$
 Alarm + pre-alarm or alarm function with 2 SPDT contact
 Field-selectable negative or positive security (fail safe)
 Automatic permanent test
 Automatic restart (up to 10 attempts) in case of transient earth fault
 "No trip" TEST (local, without output relay tripping)
 Sealable front frame

	$I_{\Delta n}$ (A)	V_n	t (s)
RD4B211B	0.03...30A	24Vac	0-0.06-0.15-0.31- 0.5-1-4.5
RD4B212B		115Vac	
RD4B213B		230Vac	
RD4B215B		400Vac	
RD4B21HB		20...150Vdc + 48Vac	

Technical features

TECHNICAL NOTES	NT871
INPUT	
Reference specification:	EN60947-2 IEC60947-2
Connection:	low voltage lines, with series TD transformer
Waveform $I_{\Delta n}$:	sinusoidal (type AC) or chopped pulsating with superimposed dc (type A) according to EN60947-2 (annex B and M) IEC60947-2
Rated frequency frn:	50Hz
Working frequency:	47...63Hz
SET UP	
Current set point $I_{\Delta n}$:	selectable by 7-position potentiometer, 3 ranges x1 - x10 - x100
Ranges $I_{\Delta n}$:	0.03 - 0.05 - 0.075 - 0.1 - 0.15 - 0.2 - 0.3 (x1 - x10 - x100)
Non-operating residual current:	0.5 $I_{\Delta n}$
Adjustable Intervention time t:	0-0,06-0,15-0,31-0,5-1-4,5s
SIGNALING AND ALARM	
Power ON:	green LED "ON"
Instantaneous value $I_{\Delta n}$:	4 LED's, 20 - 30 - 40 - 50% of set $I_{\Delta n}$ value
Alarm intervention:	red LED "TRIP" + relay switching
Ring current transformer-relay connection failure:	red LED "TRIP" blinking + relay switching
TRIP state memorization:	1 red LED "TRIP" + relay self-retaining
Reset:	manual or automatic, selectable by dip switch
Local manual:	front key
Remote manual:	external contact closing
Automatic:	10 restart attempts (30s...256 min)
Inhibited reset with persistent residual current:	> 50% $I_{\Delta n}$
OUTPUT	
Relay:	1 SPDT contact
Contact range:	5A 250Vac $\cos\phi$ 1 - 3A 250Vac $\cos\phi$ 0.4 - 5A 30Vdc
AUXILIARY SUPPLY	
Rated value U_{aux} :	24V - 48V - 115V - 230V - 240V - 400V
Tolerance:	0,85...1,1 U_{aux} - 40...60V (U_{aux} 48V)
Rated frequency:	50Hz (47...63Hz)
Rated burden:	\leq 2,5VA
Rated value U_{aux} :	20...150Vdc
Protected against incorrect polarity:	yes
Rated burden:	\leq 2,5W
Immunity to short interruption of supply voltage up to 300ms (Rated U_{aux})	
TESTS FOR ELECTROMAGNETIC COMPATIBILITY	
Emission/Immunity tests according to	EN / IEC 60947-2
ENVIRONMENTAL CONDITIONS	
Nominal temperature range:	-5...50°C
Limit temperature range for storage:	-40...70°C
Suitable for tropical climates:	yes
Max. power dissipation:	\leq 2W *
MECHANICAL FEATURES	
Housing:	4 module DIN 43880 (35mm)
Front frame:	sealable to avoid improper opening
Connections:	screw terminals for cable up to 4 mm ²
Housing material:	self-extinguishing polycarbonate
Protection degree (EN / IEC 60529):	IP40 front frame, IP20 terminals

* for switchboard thermal calculation

Wiring diagrams

DELTA D4-S

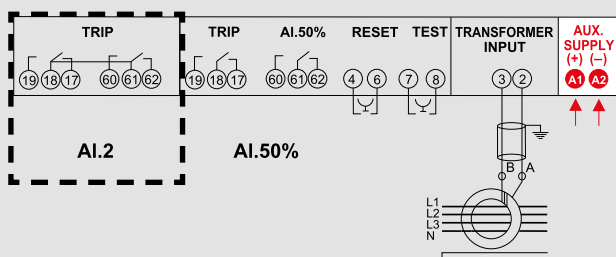

Residual current relay

Residual current relay A type 4 module with powered filter



Cat. Nos. **DELTA D4-f**

Instantaneous ($t = 0$) at I_{dn} 30mA
 Selectable set point 30mA...30A (19 ranges)
 Instantaneous display as percentage of I_{dn}
 Filter for harmonics, field-selectable
 Alarm function + pre-alarm or alarm + power fail signaling
 Field selectable negative or positive security
 Automatic permanent test

	I_{dn} (A)	V_n	t (s)
RD3B211B	0.03...30A	24Vac	0-0.15-0.25-0.5- 1-2.5-5
RD3B212B		115Vac	
RD3B213B		230Vac	
RD3B215B		400Vac	
RD3B21HB		20...150Vdc + 48Vac	

Technical features

TECHNICAL NOTES	NT865
INPUT	
Reference specification:	EN60947-2 IEC60947-2
Connection:	low voltage lines, with series TD transformer
Waveform $I_{\Delta n}$:	sinusoidal (type AC) or chopped pulsating with superimposed dc (type A) according to EN60947-2 (annex B and M) IEC60947-2
Rated frequency fn:	50Hz
Working frequency:	47...63Hz
SET UP	
Current set point $I_{\Delta n}$:	selectable by 7-position potentiometer, 3 ranges x1 - x10 - x100
Ranges $I_{\Delta n}$:	0.03 - 0.05 - 0.075 - 0.1 - 0.15 - 0.2 - 0.3 (x1 - x10 - x100)
Non-operating residual current:	0.5 $I_{\Delta n}$
Adjustable Intervention time t:	0-0,15-0,25-0,5-1-2,5-5s
SIGNALING AND ALARM	
Power ON:	green LED "ON"
Alarm intervention:	red LED "TRIP" + relay switching
Ring current transformer-relay connection failure:	red LED "TRIP" blinking + relay switching
TRIP state memorization:	1 red LED "TRIP" + relay self-retaining
Reset:	manual or automatic, selectable by dip switch
Local manual:	front key
Remote manual:	external contact closing
Automatic:	10 restart attempts (30s...256 min)
Inhibited reset with persistent residual current:	> 50% $I_{\Delta n}$
OUTPUT	
Relay:	1 SPDT contact
Contact range:	5A 250Vac $\cos\phi$ 1 - 3A 250Vac $\cos\phi$ 0.4 - 5A 30Vdc
AUXILIARY SUPPLY	
Rated value U_{aux} :	24V - 48V - 115V - 230V - 240V - 400V
Tolerance:	0,85...1,1 U_{aux} - 40...60V (U_{aux} 48V)
Rated frequency:	50Hz (47...63Hz)
Rated burden:	\leq 2.5VA
Rated value U_{aux} :	20...150Vdc
Protected against incorrect polarity:	yes
Rated burden:	\leq 2.5W
Immunity to short interruption of supply voltage up to 300ms (Rated U_{aux})	
TESTS FOR ELECTROMAGNETIC COMPATIBILITY	
Emission/Immunity tests according to	EN / IEC 60947-2
ENVIRONMENTAL CONDITIONS	
Nominal temperature range:	-5...50°C
Limit temperature range for storage:	-40...70°C
Suitable for tropical climates:	yes
Max. power dissipation:	\leq 2W *
MECHANICAL FEATURES	
Housing:	4 module DIN 43880 (35mm)
Front frame:	sealable to avoid improper opening
Connections:	screw terminals for cable up to 4 mm ²
Housing material:	self-extinguishing polycarbonate
Protection degree (EN / IEC 60529):	IP40 front frame, IP20 terminals

* for switchboard thermal calculation

Wiring diagrams

DELTA D4-F

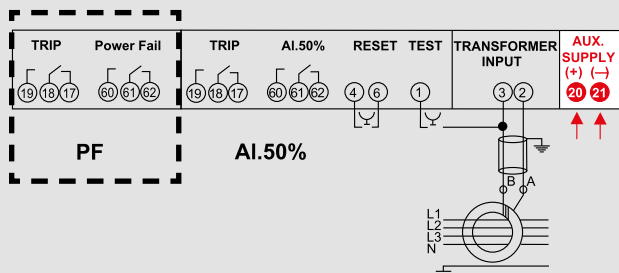

Residual current relay

Residual current relay A type 4 module LED display



- Type A (EN/IEC 60947-2 annex B and M)
- Selectable set point and delay
- Alarm + pre-alarm or alarm function with 2 SPDT contacts
- Selectable filter for harmonic components
- Instantaneous display $I_{\Delta n}$
- Automatic permanent test
- "No trip" TEST (without output relay tripping)
- Manual or automatic RESET
- RS485 communication

Cat. Nos.	DELTA D4-h		
	$I_{\Delta n}$ (A)	V_n	Pre alarm
RDD42130	0.03...30A	230Vac	20/30/40/50% $I_{\Delta n}$
RDD421H0		20...150Vdc+48Vac	
RDD42131		230Vac	
RDD421H1		20...150Vdc+48Vac	

Technical features

TECHNICAL NOTES	NT897
INPUT	
Reference specification:	EN60947-2 IEC60947-2
Connection:	low voltage lines, with series TD transformer
Waveform $I_{\Delta n}$:	sinusoidal (type AC) or chopped pulsating with superimposed d.c. (type A) according to EN60947-2 (annex B and M) IEC60947-2
Rated frequency f_n :	50Hz
Working frequency:	47...63Hz
SET UP	
Current set point $I_{\Delta n}$:	selectable by 7-position potentiometer, 3 ranges $\times 1 \times 10 \times 100$
Ranges $I_{\Delta n}$:	0.03-0.05-0.075-0.1-0.15-0.2-0.3 ($\times 1 \times 10 \times 100$)
Non-operating residual current :	0,5 $I_{\Delta n}$
Adjustable range t:	0 - 0,15 - 0,25 - 0,5 - 1 - 2,5 - 5 seconds
SIGNALING	
Display:	red LED, 1000 points (3 digits)
Display:	instantaneous value $I_{\Delta n}$ / threshold value $I_{\Delta n}$ / delay Δt
Alarm intervention:	message "ALL" + relay switching 1
Ring current transformer-relay connection failure:	message "Ct" + relay 1 switching
CONTROL	
Manual test:	it verifies the perfect working of the residual current relay
Local:	front key
Automatic continuous test:	it verifies the integrity of the connection between relay and ring core
ALARM	
TRIP state memorization	"ALL" message + relay self-retaining 1
Manual reset:	local or remote
Local manual reset:	Reset key
Remote manual reset:	external contact closing
Pre-alarm:	20 - 30 - 40 - 50% selected $I_{\Delta n}$
Inhibited reset with persistent residual current:	> 50% $I_{\Delta n}$
OUTPUT	
Relay:	2 SPDT contacts
Contact range:	5A 250Vac $\cos\phi$ 1 - 3A 250Vac $\cos\phi$ 0,4 - 5A 30Vdc
RS485 COMMUNICATION	
Standard:	RS485 - 3-wire
Protocol:	ModBus RTU / TCP
Baud rate	4800...38400 bit/s
AUXILIARY SUPPLY	
Rated value U_{aux} :	230V-48V
Tolerance:	0,85...1,1 U_{aux} 40...60V (U_{aux} 48V)
Rated frequency:	50Hz
Tolerance:	47...63Hz
Rated burden:	$\leq 2,5VA$
Immunity to short interruption of supply voltage up to 150ms (Rated U_{aux})	
ENVIRONMENTAL CONDITIONS	
Nominal temperature range:	-5...50°C
Limit temperature range for storage:	-40...70°C
Suitable for tropical climates	yes
Max. power dissipation :	$\leq 3W$ *
MECHANICAL FEATURES	
Housing:	4 module DIN 43880 (35mm)
Connections:	screw terminals for cable up to 4mm ²
Housing material:	self-extinguishing polycarbonate
Protection degree (EN/IEC 60529):	IP40 front frame, IP20 terminals

* for switchboard thermal calculation

Wiring diagrams

DELTA D4-H

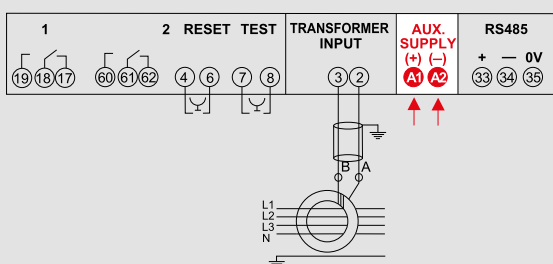

Residual current relay

Residual current relay for public lighting and traffic light plants



Use in unattended environments (public lighting, traffic lights plants)
 Automatic reset (max.3 attempts) in the event of transient ground fault
 Instantaneous ($t = 0$) at $I_{\Delta n}$ 30mA
 Selectable set point: 30mA...30A (19 ranges)
 Instantaneous display as percentage of $I_{\Delta n}$
 Filter for harmonics, field-selectable
 Field-selectable negative or positive security (fail safe)
 Automatic permanent test

Cat. Nos.	DELTA D4-I		
	$I_{\Delta n}$ (A)	V_n	t (s)
RD2B213B	0.03...30A	230Vac	0-0.06-0.15-0.31-0.5-1-4.5

Technical features

TECHNICAL NOTES	NT748
INPUT	
Reference specification:	EN60947-2 IEC60947-2
Connection:	low voltage lines, with series TD transformer
Waveform $I_{\Delta n}$:	sinusoidal (type AC) or chopped pulsating with superimposed d.c. (type A) according to EN60947-2 (annex B and M) IEC60947-2
Rated frequency f_n :	50Hz
Working frequency:	47...63Hz
SET UP	
Current set point $I_{\Delta n}$:	selectable by 7-position potentiometer, 3 ranges x1-x10-x00
Ranges $I_{\Delta n}$:	0.03-0.05-0.075-0.1-0.15-0.2-0.3 (x1-x10-x100)
Non-operating residual current :	0,5 $I_{\Delta n}$
Adjustable range t:	0 - 0,15 - 0,25 - 0,5 - 1 - 2,5 - 5 seconds
R2 relay (60-61-62) has a 0,4 second extra delay compared to the value of the selected intervention delay of the R1 relay (17-18-19). Selecting the intervention threshold on position 0,03 the intervention delay is automatically excluded, independently of position of range selector (x1/10/100).	
SIGNALING	
Power ON:	green LED "ON"
Instantaneous value $I_{\Delta n}$:	4 yellow LED's, 20-30-40-50% of set $I_{\Delta n}$ value
Alarm intervention:	red LED "TRIP" + relay switching
Ring current transformer-relay connection failure:	red LED "TRIP" blinking + relay switching
CONTROL	
Manual test:	it verifies the perfect working of the residual current relay
Local:	front key
Automatic continuous test:	it verifies the integrity of the connection between relay and ring core
ALARM	
The alarm reset can be manually or automatically made (selectable)	
Reset manual:	local or remote
Local:	front key
Remote:	external contact closing
Inhibited reset with persistent residual current:	> 50% $I_{\Delta n}$
OUTPUT	
Relay:	2 SPDT contacts
Contact range:	5A 250Vac $\cos\phi$ 1 - 3A 250Vac $\cos\phi$ 0,4 - 5A 30Vdc
Negative security (normally de-energised relay) or positive security fail safe (normally energised relay) selectable by dip switch R2 (60-61-62) is always normally de-energised relay	
AUXILIARY SUPPLY	
Rated value U_{aux} :	230V
Tolerance:	0,85...1,1 U_{aux}
Rated frequency:	50Hz
Tolerance:	47...63Hz
Rated burden:	\leq 2,5VA
Immunity to short interruption of supply voltage up to 150ms (Rated U_{aux})	
ENVIRONMENTAL CONDITIONS	
Nominal temperature range:	-5...50°C
Limit temperature range for storage:	-40...70°C
Suitable for tropical climates	yes
Max. power dissipation :	\leq 2W *
MECHANICAL FEATURES	
Housing:	4 module DIN 43880 (35mm)
Connections:	screw terminals for cable up to 4mm ²
Housing material:	self-extinguishing polycarbonate
Protection degree (EN/IEC 60529):	IP40 front frame, IP20 terminals

* for switchboard thermal calculation

Wiring diagrams

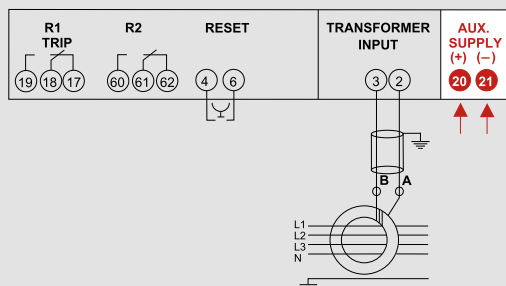

Residual current relay

Residual current relay A type flush mounting 48 x 48 cm



Istantaneous ($t = 0$) at $I_{\Delta n}$ 30mA
 Selectable set point: 30mA...30A (19 ranges)
 Field-selectable negative or positive security (fail safe)
 Automatic permanent test
 Manual or automatic reset (3 restart attempts)

Cat. Nos.		DELTA 48-s		$I_{\Delta n}$ (A)	V_n	t (s)
1 alarm contact	2 alarm contacts					
RD1DF11B	RD1D211B			0.03...30A	24Vac	0-0.15-
RD1DF12B	RD1D212B				115Vac	0.25-0.5-
RD1DF13B	RD1D213B				230Vac	1-2.5-5
RD1DF15B	RD1D215B				400Vac	
RD1DF1HB	RD1D21HB				20...150Vdc+ 48Vac	

Technical features

MODEL	(RD1DF...)	(RD1D2...)
TECHNICAL NOTES	NT556	NT711
INPUT		
Reference specification	EN60947-2 IEC60947-2	
Connection	low voltage lines, with series TD transformer	
Waveform $I_{\Delta n}$	sinusoidal (type AC) or chopped pulsating with superimposed dc (type A) according to EN60947-2 (annex B and M) IEC60947-2	
Rated frequency f_n	50Hz	
Working frequency	47...63Hz	
SET UP		
Current set point $I_{\Delta n}$	selectable by 7-position potentiometer, 3 ranges x1 - x10 - x100	
Ranges $I_{\Delta n}$	0.03 - 0.05 - 0.075 - 0.1 - 0.15 - 0.2 - 0.3 (x1 - x10 - x100)	
Non-operating residual current	0.5 $I_{\Delta n}$	
Adjustable Intervention time t	0-0,15-0,25-0,5-1-2,5-5s	
SIGNALING AND ALARM		
Power ON	green LED "ON"	
Alarm intervention	red LED "TRIP" + relay switching	
Ring current transformer-relay connection failure	red LED "TRIP" blinking + relay switching	
TRIP state memorization	1 red LED "TRIP" + relay self-retaining	
Reset	manual or automatic, selectable by dip switch	
Local manual	front key	
Remote manual	external contact closing	
Automatic	3 restart attempts (1 each 60 seconds)	
Inhibited reset with persistent residual current	> 50% $I_{\Delta n}$	
OUTPUT		
Relay	1 SPDT contact or 1 SPDT contact + 1 SPST contact	
Contact range	5A 250Vac $\cos\phi$ 1 - 3A 250Vac $\cos\phi$ 0.4 - 5A 30Vdc	

AUXILIARY SUPPLY	
Rated value U_{aux}	24V - 48V - 115V - 230V - 240V - 400V
Tolerance	0,85...1,1 U_{aux} - 40...60V (U_{aux} 48V)
Rated frequency	50Hz (47...63Hz)
Rated burden	\leq 2.5VA
Rated value U_{aux}	20...150Vdc
Protected against incorrect polarity	yes
Rated burden	\leq 2.5W
Immunity to short interruption of supply voltage up to 300ms (Rated U_{aux})	

TESTS FOR ELECTROMAGNETIC COMPATIBILITY	
Emission/Immunity tests according to	EN / IEC 60947-2

ENVIRONMENTAL CONDITIONS	
Nominal temperature range	-5...50°C
Limit temperature range for storage	-40...70°C
Suitable for tropical climates	yes
Max. power dissipation	\leq 2W *

MECHANICAL FEATURES	
Housing	flush mounting (panel cutout 45x45mm)
Depth	102mm
Front frame	48x48 mm (52x52 with IP54 option)
Connections	fast-ons 6,3 x 0,8 mm
Housing material	self-extinguishing polycarbonate
Protection degree (EN / IEC 60529)	IP40 front frame, IP20 terminals (option kit for IP54 front frame protection)

* for switchboard thermal calculation

Wiring diagrams

1 alarm contact

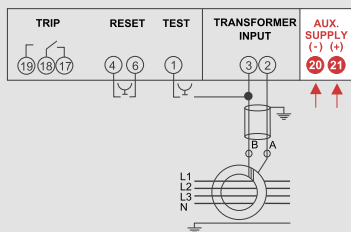

2 alarm contacts

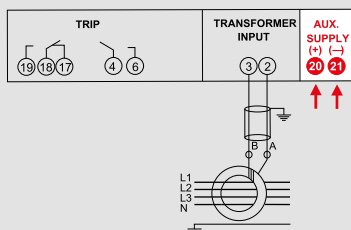

Residual current relay

Residual current relay A type flush mounting 72 x 72 cm



- Instantaneous ($t = 0$) at $I_{\Delta n}$ 30mA
- Selectable set point 30mA...30A (19 ranges)
- Instantaneous display as percentage of $I_{\Delta n}$
- Pre-alarm threshold
- Field-selectable negative or positive security (fail safe)
- Automatic permanent test
- Manual or automatic reset (3 restart attempts)

Cat. Nos.		DELTA 72-s		
2 contact (alarm + pre-alarm)	2 contact (alarm or alarm + pre-alarm)	$I_{\Delta n}$ (A)	V_n	t (s)
RD1EP11B	RD1E211B	0.03...30A	24Vac	0-0.15- 0.25-0.5- 1-2.5-5
RD1EP12B	RD1E212B		115Vac	
RD1EP13B	RD1E213B		230Vac	
RD1EP15B	RD1E215B		400Vac	
RD1EP1HB	RD1E21HB		20...150Vdc+ 48Vac	

Technical features

MODEL	(RD1EP...)	(RD1E2...)
TECHNICAL NOTES	NT552	NT692
INPUT		
Reference specification	EN60947-2 IEC60947-2	
Connection	low voltage lines, with series TD transformer	
Waveform $I_{\Delta n}$	sinusoidal (type AC) or chopped pulsating with superimposed dc (type A) according to EN60947-2 (annex B and M) IEC60947-2	
Rated frequency f_n	50Hz	
Working frequency	47...63Hz	
SET UP		
Current set point $I_{\Delta n}$	selectable by 7-position potentiometer, 3 ranges x1 - x10 - x100	
Ranges $I_{\Delta n}$	0.03 - 0.05 - 0.075 - 0.1 - 0.15 - 0.2 - 0.3 (x1 - x10 - x100)	
Non-operating residual current	0.5 $I_{\Delta n}$	
Adjustable Intervention time t	0-0,15-0,25-0,5-1-2,5-5s	
SIGNALING AND ALARM		
Power ON	green LED "ON"	
Instantaneous value $I_{\Delta n}$	4 yellow LED's, 20 - 30 - 40 - 50% of set $I_{\Delta n}$ value	
Alarm intervention	red LED "TRIP" + relay switching	
Ring current transformer-relay connection failure	red LED "TRIP" blinking + relay switching	
Pre-alarm	50% $I_{\Delta n}$ relay switching	
TRIP state memorization	1 red LED "TRIP" + relay self-retaining	
Reset	manual or automatic, selectable by dip switch	
Local manual	front key	
Remote manual	external contact closing	
Automatic	3 restart attempts (1 each 60 seconds)	
Inhibited reset with persistent residual current	> 50% $I_{\Delta n}$	
OUTPUT		
50% $I_{\Delta n}$ relay	1 SPDT contact (Negative security)	
Trip relay	1 SPDT contact	
Contact range	5A 250Vac $\cos\phi$ 1 - 3A 250Vac $\cos\phi$ 0.4 - 5A 30Vdc	
AUXILIARY SUPPLY		
Rated value U_{aux}	24V - 48V - 115V - 230V - 240V - 400V	
Tolerance	0,85...1,1 U_{aux} - 40...60V (U_{aux} 48V)	
Rated frequency	50Hz (47...63Hz)	
Rated burden	$\leq 2.5VA$	
Rated value U_{aux}	20...150Vdc	
Protected against incorrect polarity	yes	
Rated burden	$\leq 2.5W$	
Immunity to short interruption of supply voltage up to 300ms (Rated U_{aux})		
TESTS FOR ELECTROMAGNETIC COMPATIBILITY		
Emission/Immunity tests according to	EN / IEC 60947-2	
ENVIRONMENTAL CONDITIONS		
Nominal temperature range	-5...50°C	
Limit temperature range for storage	-40...70°C	
Suitable for tropical climates	yes	
Max. power dissipation	$\leq 2W$ *	
MECHANICAL FEATURES		
Housing	flush mounting (panel cutout 68x68mm)	
Depth	75mm	
Front frame	72x72 mm	
Connections	fast-ons 6,3 x 0,8 mm	
Housing material	self-extinguishing polycarbonate	
Protection degree (EN / IEC 60529)	IP40 front frame, IP20 terminals	

* for switchboard thermal calculation

Wiring diagrams

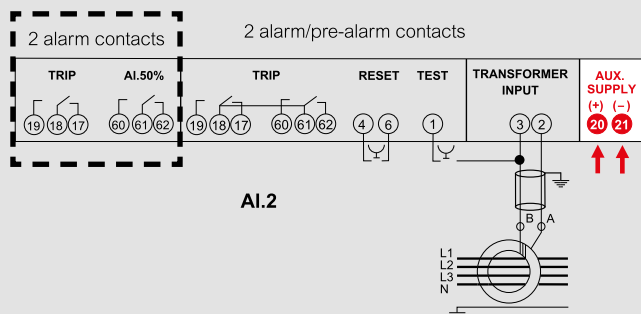

Residual current relay

Residual current relay A type flush mounting 72 x 72 cm LED display



Instantaneous ($t = 0$) at $I_{\Delta n}$ 30mA
 Selectable set point 30mA...30A (19 ranges)
 Instantaneous display of $I_{\Delta n}$
 Alarm + pre-alarm or alarm with 2 contacts
 Field-selectable negative or positive security (fail safe)
 Automatic permanent test

Cat. Nos.	DELTA 72-h		
	$I_{\Delta n}$ (A)	V_n	t (s)
RD3E211B	0.03...30A	24Vac	0-0.15-0.25- 0.5-1-2.5-5
RD3E212B		115Vac	
RD3E217B		230Vac	
RD3E218B		400Vac	
RD3E21HB		20...150Vdc + 48Vac	

Technical features

TECHNICAL NOTES	NT649
INPUT	
Reference specification	EN60947-2 IEC60947-2
Connection	low voltage lines, with series TD transformer
Waveform $I_{\Delta n}$	sinusoidal (type AC) or chopped pulsating with superimposed dc (type A) according to EN60947-2 (annex B and M) IEC60947-2
Rated frequency f_n	50Hz
Working frequency	47...63Hz
SET UP	
Current set point $I_{\Delta n}$	selectable by 7-position potentiometer, 3 ranges $\times 1 - \times 10 - \times 100$
Ranges $I_{\Delta n}$	0.03 - 0.05 - 0.075 - 0.1 - 0.15 - 0.2 - 0.3 ($\times 1 - \times 10 - \times 100$)
Non-operating residual current	0.5 $I_{\Delta n}$
Adjustable Intervention time t	0-0,15-0,25-0,5-1-2,5-5s
SIGNALING AND ALARM	
Power ON	green LED "ON"
Instantaneous value $I_{\Delta n}$	4 yellow LED's, 20 - 30 - 40 - 50% of set $I_{\Delta n}$ value
Alarm intervention	"AL" message blinking + "FAULT" relay switching
Ring current transformer-relay connection failure	"CT" message blinking + "FAULT" relay switching
Pre-alarm	"ALARM" relay switching
Manual test	"AL" message fixed + "FAULT" relay switching
Instantaneous value $I_{\Delta n}$	1000 points display (3 digit)
Display type	red LED, 7 segments
Digit height	10mm
Accuracy	$\pm 5\% + 1$ digit (referred to measuring full scale)
ELR measuring range	10...100% selected $I_{\Delta n}$
OUTPUT	
Alarm relay (FAULT) + pre-alarm (ALARM)	FAULT relay 1 SPDT contact ALARM relay 1 SPST contact
Alarm relay with 2 contacts	1 SPDT contacts + 1 SPST contact
Contact range	5A 250Vac $\cos\phi$ 1 - 3A 250Vac $\cos\phi$ 0,4 - 5A 30Vdc
AUXILIARY SUPPLY	
Rated value U_{aux}	24V - 48V - 115V - 230V - 240V - 400V
Tolerance	0,85...1,1 U_{aux} - 40...60V (U_{aux} 48V)
Rated frequency	50Hz (47...63Hz)
Rated burden	$\leq 4VA$
Rated value U_{aux}	20...150Vdc
Protected against incorrect polarity	yes
Rated burden	$\leq 4W$
Immunity to short interruption of supply voltage up to 150ms (Rated U_{aux})	
TESTS FOR ELECTROMAGNETIC COMPATIBILITY	
Emission/Immunity tests according to	EN / IEC 60947-2
ENVIRONMENTAL CONDITIONS	
Nominal temperature range	-25...55°C
Limit temperature range for storage	-40...85°C
Suitable for tropical climates	yes
Max. power dissipation	$\leq 2.5W$ *
MECHANICAL FEATURES	
Housing	flush mounting (panel cutout 68x68mm)
Depth	81.8mm
Front frame	72x72 mm
Connections	extractable terminals, screw terminals for cable up to 4mm ²
Housing material	self-extinguishing polycarbonate
Protection degree (EN / IEC 60529)	IP40 front frame, IP20 terminals

* for switchboard thermal calculation

Wiring diagrams

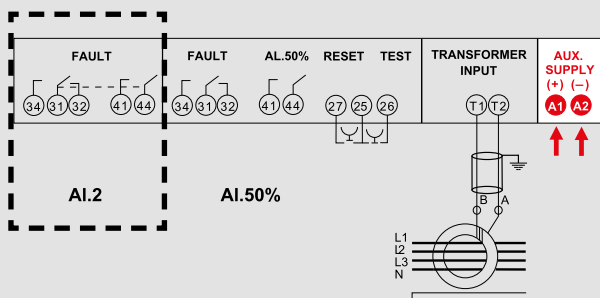

Residual current relay

Residual current relay A type flush mounting 72 x 72 cm with powered filter



Heavy industrial applications with distorted current waveforms:
inverters, variable speed drives, rectifiers, frequency regulators
Filter for harmonics

- It cannot be used to protect people
- Selectable set point 50mA...30A (18 ranges)
- Instantaneous display as percentage of I_{Δn}
- Field-selectable negative or positive security (fail safe)
- Automatic permanent test
- Alarm relay + pre-alarm or alarm relay with double exchange

Cat. Nos.	DELTA 72-f		
	I _{Δn} (A)	V _n	t (s)
RD2E211B	0.05...30A	24Vac	0-0.15-0.25- 0.5-1-2.5-5
RD2E212B		115Vac	
RD2E213B		230Vac	
RD2E215B		400Vac	
RD2E21HB		20...150Vdc+ 48Vac	

Technical features

TECHNICAL NOTES	NT745
INPUT	
Reference specification	EN60947-2 IEC60947-2
Connection	low voltage lines, with series TD transformer
Waveform I _{Δn}	sinusoidal (type AC) or chopped pulsating with superimposed dc (type A) according to EN60947-2 (annex B and M) IEC60947-2
Rated frequency f _n	50Hz
Working frequency	47...63Hz
SET UP	
Current set point I _{Δn}	selectable by 6-position potentiometer, 3 ranges x1 - x10 - x100
Ranges I _{Δn}	0.05-0, 0.75-0.1-0.15-0.2-0.3 (x1-x10-x100)
Non-operating residual current	0.5 I _{Δn}
Adjustable Intervention time t	0-0,15-0,25-0,5-1-2,5-5s
SIGNALING AND ALARM	
Power ON	green LED "ON"
Instantaneous value I _{Δn}	4 yellow LED's, 20 - 30 - 40 - 50% of set I _{Δn} value
Alarm intervention	red LED "TRIP" + "TRIP" relay switching
Ring current transformer-relay connection failure	red LED "TRIP" blinking + "TRIP" relay switching
Pre-alarm	50% I _{Δn} relay switching
Manual test	it verifies the perfect working of the residual current relay
Local	front key
Remote	by external contact closing (Not available with dc supply and U _{aux} 48Vac)
Automatic continuous test	verifies the integrity of the connection between relay and ring core
OUTPUT	
Alarm relay with double exchange (Al.2)	2 SPDT contacts
Alarm + pre-alarm (Al.50%)	1 SPDT contact
50% I _{Δn} relay	SPDT contact (negative security)
Contact range	5A 250Vac cosφ 1 - 3A 250Vac cosφ 0.4 - 5A 30Vdc
AUXILIARY SUPPLY	
Rated value U _{aux}	24V - 48V - 115V - 230V - 240V - 400V
Tolerance	0,85...1,1U _{aux} - 40...60V (U _{aux} 48V)
Rated frequency	50Hz (47...63Hz)
Rated burden	≤ 2.5VA
Rated value U _{aux}	20...150Vdc
Protected against incorrect polarity	yes
Rated burden	≤ 2.5W
Immunity to short interruption of supply voltage up to 150ms (Rated U _{aux})	
TESTS FOR ELECTROMAGNETIC COMPATIBILITY	
Emission/Immunity tests according to	EN / IEC 60947-2
ENVIRONMENTAL CONDITIONS	
Nominal temperature range	-5...50°C
Limit temperature range for storage	-40...70°C
Suitable for tropical climates	yes
Max. power dissipation	≤ 2W *
MECHANICAL FEATURES	
Housing	flush mounting (panel cutout 68x68mm)
Depth	75mm
Front frame	72x72mm (75x75 mm with IP54 option)
Connections	extractable terminals, screw terminals for cable up to 4mm ²
Housing material	self-extinguishing polycarbonate
Protection degree (EN / IEC 60529)	IP40 front frame, IP20 terminals

* for switchboard thermal calculation

Wiring diagrams

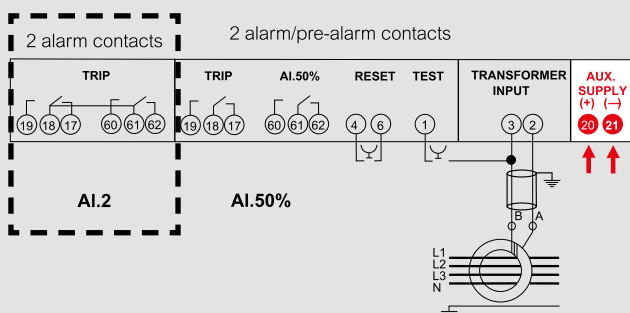

Residual current relay

Residual current relay A type flush mounting 96 x 96 cm



- Instantaneous ($t = 0$) at $I_{\Delta n}$ 30mA
- Selectable set point 30mA...30A (19 ranges)
- Instantaneous display as percentage of $I_{\Delta n}$
- Field-selectable negative or positive security (fail safe)
- Automatic permanent test
- Alarm relay + pre-alarm or alarm relay with double exchange

Cat. Nos.	DELTA 96-s		
	$I_{\Delta n}$ (A)	V_n	t (s)
RD1G211B	0.03...30A	24Vac	0-0.15-0.25- 0.5-1-2.5-5
RD1G212B		115Vac	
RD1G213B		230Vac	
RD1G215B		400Vac	
RD1G215B		400Vac	
RD1G211B		20...150Vdc+ 48Vac	

Technical features

TECHNICAL NOTES	NT691
INPUT	
Reference specification	EN60947-2 IEC60947-2
Connection	low voltage lines, with series TD transformer
Waveform $I_{\Delta n}$	sinusoidal (type AC) or chopped pulsating with superimposed dc (type A) according to EN60947-2 (annex B and M) IEC60947-2
Rated frequency f_n	50Hz
Working frequency	47...63Hz
SET UP	
Current set point $I_{\Delta n}$	selectable by 7-position potentiometer, 3 ranges $\times 1 - \times 10 - \times 100$
Ranges $I_{\Delta n}$	0.03-0.05-0.075-0.1-0.15-0.2-0.3 ($\times 1-\times 10-\times 100$)
Non-operating residual current	0.5 $I_{\Delta n}$
Adjustable Intervention time t	0-0,15-0,25-0,5-1-2,5-5s
SIGNALING AND ALARM	
Power ON	green LED "ON"
Instantaneous value $I_{\Delta n}$	4 yellow LED's, 20 - 30 - 40 - 50% of set $I_{\Delta n}$ value
Alarm intervention	red LED "TRIP" + "TRIP" relay switching
Ring current transformer-relay connection failure	red LED "TRIP" blinking + "TRIP" relay switching
Pre-alarm	50% $I_{\Delta n}$ relay switching
Manual test	it verifies the perfect working of the residual current relay
Local	front key
Remote	by external contact closing (Not available with dc supply and Uaux 48Vdc)
Automatic continuous test	verifies the integrity of the connection between relay and ring core
OUTPUT	
Alarm relay with double exchange (AI.2)	2 SPDT contacts
Alarm + pre-alarm (AI.50%)	1 SPDT contact
50% $I_{\Delta n}$ relay	SPDT contact (negative security)
Contact range	5A 250Vac $\cos\phi$ 1 - 3A 250Vac $\cos\phi$ 0.4 - 5A 30Vdc
AUXILIARY SUPPLY	
Rated value U_{aux}	24V - 48V - 115V - 230V - 240V - 400V
Tolerance	0,85...1,1 U_{aux} - 40...60V (U_{aux} 48V)
Rated frequency	50Hz (47...63Hz)
Rated burden	$\leq 2.5VA$
Rated value U_{aux}	20...150Vdc
Protected against incorrect polarity	yes
Rated burden	$\leq 2.5W$
Immunity to short interruption of supply voltage up to 150ms (Rated U_{aux})	
TESTS FOR ELECTROMAGNETIC COMPATIBILITY	
Emission/Immunity tests according to	EN / IEC 60947-2
ENVIRONMENTAL CONDITIONS	
Nominal temperature range	-5...50°C
Limit temperature range for storage	-40...70°C
Suitable for tropical climates	yes
Max. power dissipation	$\leq 2W$ *
MECHANICAL FEATURES	
Housing	flush mounting (panel cutout 92x92mm)
Depth	80mm
Front frame	96x96mm (75x75 mm with IP54 option)
Connections	fast-ons 6,3x0,8mm
Housing material	self-extinguishing polycarbonate
Protection degree (EN / IEC 60529)	IP40 front frame, IP20 terminals

* for switchboard thermal calculation

Wiring diagrams

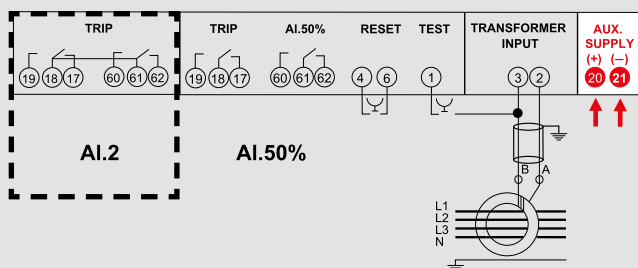

Residual current relay

Residual current relay A type flush mounting 96 x 96 cm with powered filter



Heavy industrial applications with distorted current waveforms:
 inverters, variable speed drives, rectifiers, frequency regulators
 Filter for harmonics
 It cannot be used to protect people
 Selectable set point 50mA...30A (18 ranges)
 Instantaneous display as percentage of $I_{\Delta n}$
 Field-selectable negative or positive security (fail safe)
 Automatic permanent test
 Alarm relay + pre-alarm or alarm relay with double exchange

Cat. Nos.	DELTA 96-f		
	$I_{\Delta n}$ (A)	V_n	t (s)
RD2G211B	0.05...30A	24Vac	0-0.15-0.25- 0.5-1-2.5-5
RD2G212B		115Vac	
RD2G213B		230Vac	
RD2G215B		400Vac	
RD2G21HB		20...150Vdc+ 48Vac	

Technical features

TECHNICAL NOTES	NT746
INPUT	
Reference specification	EN60947-2 IEC60947-2
Connection	low voltage lines, with series TD transformer
Waveform $I_{\Delta n}$	sinusoidal (type AC) or chopped pulsating with superimposed dc (type A) according to EN60947-2 (annex B and M) IEC60947-2
Rated frequency f_n	50Hz
Working frequency	47...63Hz
SET UP	
Current set point $I_{\Delta n}$	selectable by 6-position potentiometer, 3 ranges x1 - x10 - x100
Ranges $I_{\Delta n}$	0.05-0. 075-0.1-0.15-0.2-0.3 (x1-x10-x100)
Non-operating residual current	0.5 $I_{\Delta n}$
Adjustable Intervention time t	0-0,15-0,25-0,5-1-2,5-5s
SIGNALING AND ALARM	
Power ON	green LED "ON"
Instantaneous value $I_{\Delta n}$	4 yellow LED's, 20 - 30 - 40 - 50% of set $I_{\Delta n}$ value
Alarm intervention	red LED "TRIP" + "TRIP" relay switching
Ring current transformer-relay connection failure	red LED "TRIP" blinking + "TRIP" relay switching
Pre-alarm	50% $I_{\Delta n}$ relay switching
Manual test	it verifies the perfect working of the residual current relay
Local	front key
Remote	by external contact closing (Not available with dc supply and Uaux 48Vac)
Automatic continuous test	verifies the integrity of the connection between relay and ring core
OUTPUT	
Alarm relay with double exchange (AI.2)	2 SPDT contacts
Alarm + pre-alarm (AI.50%)	1 SPDT contact
50% $I_{\Delta n}$ relay	SPDT contact (negative security)
Contact range	5A 250Vac cosφ 1 - 3A 250Vac cosφ 0.4 - 5A 30Vdc
AUXILIARY SUPPLY	
Rated value U_{aux}	24V - 48V - 115V - 230V - 240V - 400V
Tolerance	0,85...1,1 U_{aux} - 40...60V (U_{aux} 48V)
Rated frequency	50Hz (47...63Hz)
Rated burden	≤ 2.5VA
Rated value U_{aux}	20...150Vdc
Protected against incorrect polarity	yes
Rated burden	≤ 2.5W
Immunity to short interruption of supply voltage up to 150ms (Rated U_{aux})	
TESTS FOR ELECTROMAGNETIC COMPATIBILITY	
Emission/Immunity tests according to	EN / IEC 60947-2
ENVIRONMENTAL CONDITIONS	
Nominal temperature range	-5...50°C
Limit temperature range for storage	-40...70°C
Suitable for tropical climates	yes
Max. power dissipation	≤ 2W *
MECHANICAL FEATURES	
Housing	flush mounting (panel cutout 92x92mm)
Depth	80mm
Front frame	96x96mm (75x75 mm with IP54 option)
Connections	fast-ons 6,3x0,8mm
Housing material	self-extinguishing polycarbonate
Protection degree (EN / IEC 60529)	IP40 front frame, IP20 terminals

* for switchboard thermal calculation

Wiring diagrams

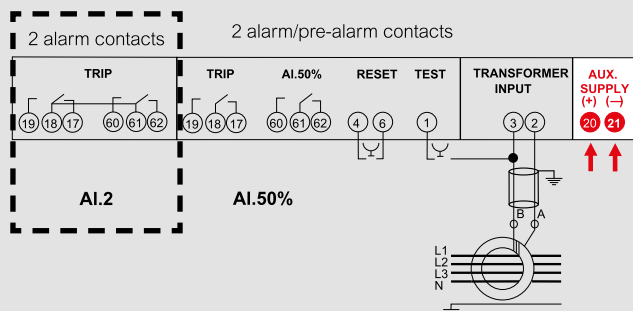

Residual current relay

Transformers for residual current relay open and close core



TDG...



TDA...

Cat. Nos.		DEL		
	I _{dn} (A)	Inside diameter (mm)	Core Type	
TDGA2	0.03	28	Closed	
TDGB2	0.03	35	Closed	
TDGH2	0.03	60	Closed	
TDGC2	0.03	80	Closed	
TDGD2	0.1	110	Closed	
TDGE2	0.3	140	Closed	
TDGF2	0.3	210	Closed	

ATADIN01 Accessory for transformers mounting on DIN35 rail

Cat. Nos.		DEL-A		
	I _{dn} (A)	Inside diameter (mm)	Core Type	
TDAA2	0.5	110	Open	
TDAB2	0.5	150	Open	
TDAC2	1	300	Open	

Technical features

TECHNICAL NOTES	NT641
SPECIFICATIONS	
Primary/secondary measuring ratio	1/700
Primary circuit	conductors of line to be protected that cross toroid hole
Test current corresponding to 6 In	I _{max} (shown values are valid only for conductors passing exactly in the middle of toroid).
I _{th} short circuit thermal current	90kA according to EN/IEC 61869-1, 61869-2
INSULATION	
Rated voltage of the monitored circuit U _n	720V (phase-neutral)
Rated power frequency withstand voltage	3kV (50Hz / 1min)
Rated impulse withstand voltage U _{imp}	8kV 1,2/50μs
ENVIRONMENTAL CONDITIONS	
Nominal range temperature(EN/IEC 60947-2)	-5÷40°C
Limit temperature range for storage	-40 ÷ 70°C
Suitable for tropical climates	yes
MECHANICAL FEATURES	
Connections	screw terminals with protection terminal cover (sealable)
Housing material	PC V0 self-extinguishing according to UL94
Mounting	screw type

Dimensions

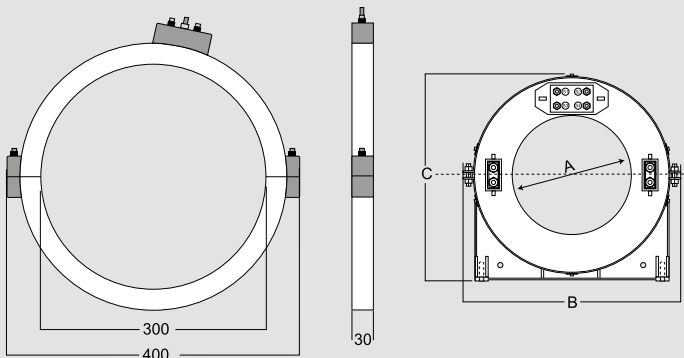

Model	A	B	C	Weight
TDAA2	110	235	219	250g
TDAB2	150	275	259	300g

Dimensions

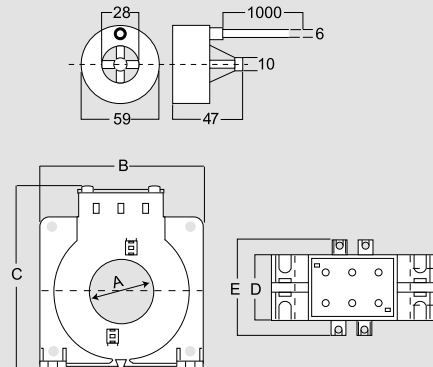

Dim. (mm)	A	B	C	D	E	Weight
TDGB2	35	92	113	36	56	250g
TDGH2	60	105	138	36	56	300g
TDGC2	80	125	160	36	56	350g
TDGD2	110	165	198	36	56	500g
TDGE2	140	200	234	36	56	700g
TDGF2	210	290	323	44	64	1200g
TDS5...	80	125	160	36	56	400g

Residual current relay

Summing ring current transformer for differential protection with measuring CT transformer



Cat. Nos.	DEL		
	I _{dn} (A)	Diameter (mm)	Core Type
TDS5C100	100/5	80	Closed
TDS5C150	150/5	80	Closed
TDS5C250	250/5	80	Closed
TDS5C400	400/5	80	Closed
TDS5C500	500/5	80	Closed
TDS5C600	600/5	80	Closed
TDS5C800	800/5	80	Closed
TDS5D100	1000/5	80	Closed
TDS5D120	1200/5	80	Closed
TDS5D125	1250/5	80	Closed
TDS5D150	1500/5	80	Closed
TDS5D160	1600/5	80	Closed
TDS5D200	2000/5	80	Closed
TDS5D250	2500/5	80	Closed
TDS5D300	3000/5	80	Closed
TDS5D320	3200/5	80	Closed
TDS5D400	4000/5	80	Closed
TDS5D500	5000/5	80	Closed

Technical features

APPLICATION

If problems with insulation or with cable or bar dimensions for the line to be protected don't allow to use ring current transformers (max. hole diameter 300mm) it is possible to use instrument current transformers with 5A secondary winding and same primary currents, accuracy class 0,5 or 1.

CHOICE OF TRANSFORMER

Transformer ratio according to the connected instrument current transformer ratio. In case of connection with instrument current transformer with ratio higher than 400/5A, the values of intervention current I_{Δn} selectable on the earth leakage relay are multiplied x10.

CONNECTION TDS5 - EARTH LEAKAGE RELAY

It should be preferably carried out with shielded cable; this precaution is of great importance when you mount high-sensitivity earth leakage relay (I_{Δn} ≤ 0,1A). Besides you have to pay particular attention to the distance between the ring current transformer and the relay (which must be as short as possible) and the closeness of power conductors or other devices which can cause noises on the system. If shielded cables cannot be used, it is advisable to twist the TDS5-relay connecting cables.

TECHNICAL NOTES	NT642
INSULATION	
Insulation voltage rating	0,72kV
A.C. voltage test 3	kV r.m.s. 50Hz / 1min
Considered circuits	measuring windings towards earth
ENVIRONMENTAL CONDITIONS	
Nominal range temperature (EN/IEC 60947-2)	-5...40°C
Limit temperature range for storage	-40...70°C
Suitable for tropical climates	yes
MECHANICAL FEATURES	
Connections	screw terminals
Housing material	self-extinguishing ABS
Mounting	screw type
Weight	400gr.

Dimensions

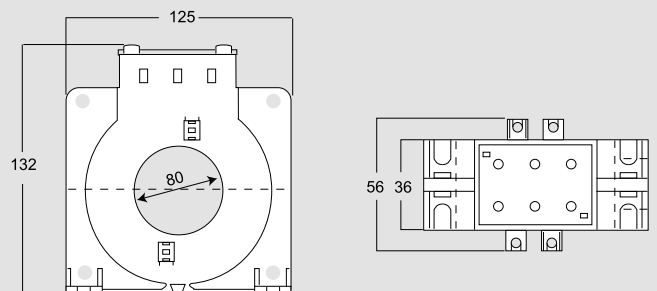

Residual current relay

Switch opening circuit monitoring unit with current launching coil



It guarantees the differential protection reliability by monitoring the release circuit working order of one or two switches with current launching coil. It reports the opening circuit breakdown by displaying the alarm (front LED) and intervention of output relay.

It can be used for all the applications which provide for the use of circuits with current launching coil to monitor its proper working order (for instance security circuits, sound or visual signalling of states of alarm, fire pumps, etc...)

Controlled circuits 1 or 2 (selectable)

Controlled circuit voltage 20...440V ac/dc

Alarm display

Alarm detection with output relay intervention

Cat. Nos.	Delta TCS		
	Vn auxiliary circuits	Vn circuits	Contacts
ARD003	230Vac	20...440Vac/dc	2
ARD00H	20...150Vdc+48Vac	20...440	2

Technical features

TECHNICAL NOTES	NT817
INPUT	
Controlled circuits	1 or 2 selectable
Controlled circuit voltage	20...440V ac/dc
Controlled circuit rated burden	≤ 1mA
SETTING	
Measurement	direct current (DC) or alternating current (AC) circuit
Controlled circuits	1 coil (F1) or 2 coils (F2)
SIGNALLING	
Monitoring (coil not broken down)	green LED "Ok"
Alarm (broken down coil)	red LED "Fault" + relay communication
CONTROL	
Manual test	it verifies the proper working order for monitoring unit and coil circuit
In the F2 function 2 Test keys which allow verifying each single circuit are available	
ALARM	
Delay	≥ 1s
Reset	automatic
Reset delay	≥ 1s
OUTPUT	
Funzione F1 Relay	2 SPDT contacts (R1+R2)
Funzione F2 Relay	1 SPDT contact (R1) + 1 SPDT contact (R2)
Contact range	5A 250Vac cosφ 1 – 3A 250Vac cosφ 0,4 – 5A 30Vdc
Positive security fail safe (normally energised relay)	
AUXILIARY SUPPLY	
Rated value Uaux ac	48 - 230V
Tolerance	0,8...1,1Uaux ac – 40...60V(Uaux ac 48V)
Rated frequency	50Hz
Tolerance	47...63Hz
Rated burden	2,5VA
Rated value Uaux dc	20...150Vdc
Protected against incorrect polarity	yes
Rated burden	2,5W
TESTS FOR ELECTROMAGNETIC COMPATIBILITY	
Emission/Immunity tests according to	EN/IEC 60947-2
ENVIRONMENTAL CONDITIONS	
Nominal temperature range	-10...50°C
Limit temperature range for storage	-40...70°C
Suitable for tropical climates	yes
Max. power dissipation *	≤ 2,5W
MECHANICAL FEATURES	
Housing	4 module DIN 43880 (35mm)
Connections	screw terminals for cable up to 4mm ²
Housing material	self-extinguishing polycarbonate
Protection degree (EN/IEC 60529)	IP40 front frame, IP20 terminals

* for switchboard thermal calculation

Wiring diagrams

